

TYPICAL TAPPING SLEEVE AND VALVE DETAIL

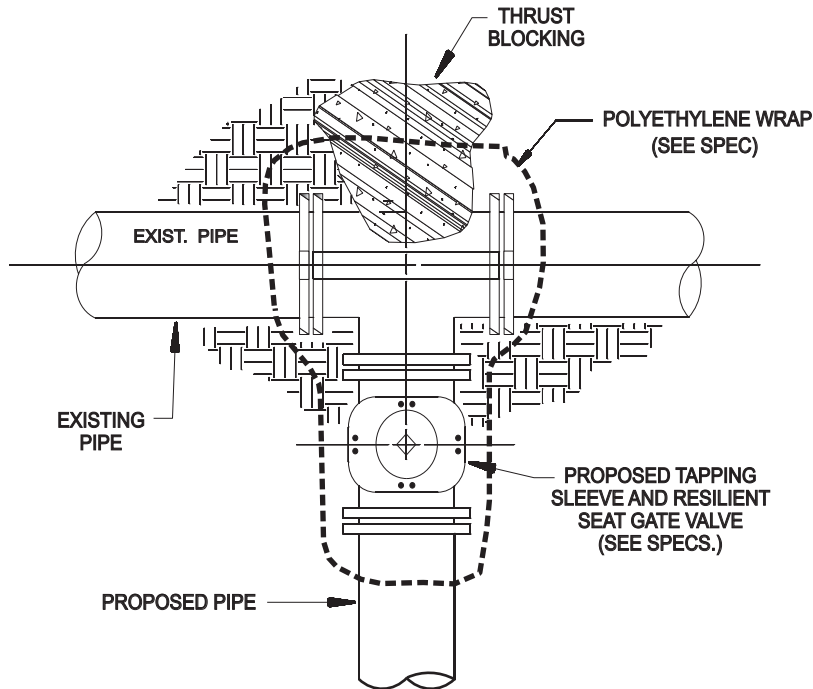

TAPPING SLEEVE AND VALVE w/ CAP

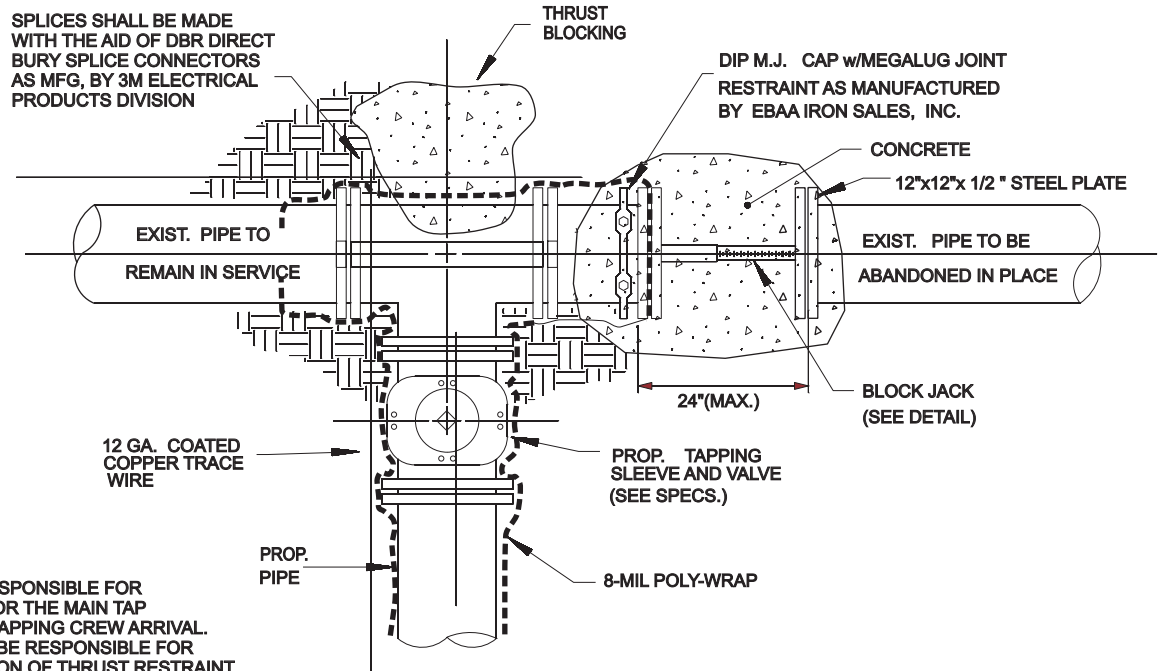

NOTE:

THE CONTRACTOR WILL BE RESPONSIBLE FOR EXPOSING AND PREP WORK FOR THE MAIN TAP PRIOR TO PADUCAH WATERS TAPPING CREW ARRIVAL. THE CONTRACTOR WILL ALSO BE RESPONSIBLE FOR THE MAIN TIE-IN, CONSTRUCTION OF THRUST RESTRAINT CONCRETE KICKER AS DESIGNED, PLACEMENT OF VALVE BOX, BACKFILL AND SURFACE RESTORATION.

PADUCAH WATER WILL BE RESPONSIBLE FOR THE TAPPING SLEEVE AND VALVE ALONG WITH INSTALLATION OF THE TAP.