

PADUCAH WATER STANDARD SPEC DRAWING NO. PW-04
GATE VALVE & BOX COLLAR DETAIL

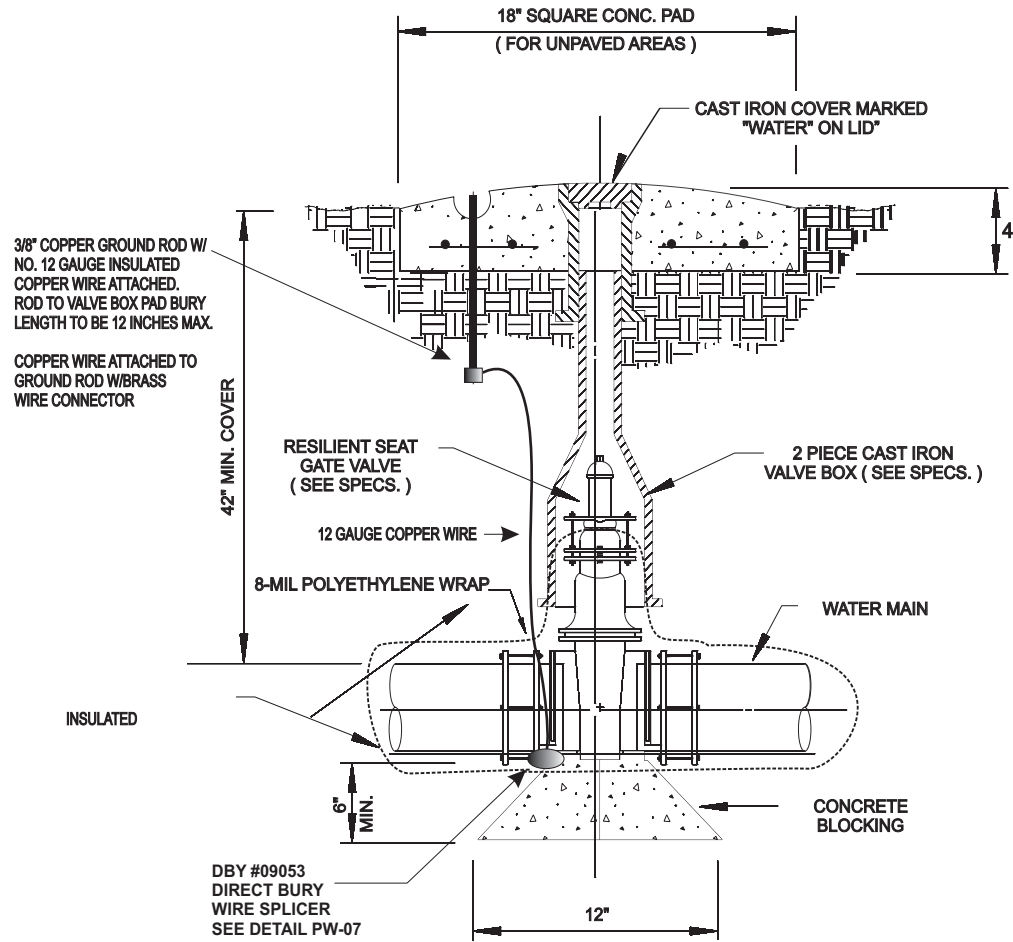

NOTE

1. CONCRETE PADS SHALL BE CONSTRUCTED AROUND ALL MAIN LINE, FIRE LINE, AND FIRE HYDRANT GATE VALVE BOXES, EXCEPT WITHIN HARD PAVED AREAS.
2. CONCRETE VALVE BOXES SHALL BE CONSTRUCTED AROUND SERVICE LINE VALVES FOR 3 INCH AND LARGER VALVES.
3. CONCRETE PADS SHALL BE CLASS "A" TYPE PORTLAND CEMENT CONCRETE WITH A WOOD FLOAT FINISH TOOLED EDGE.
4. THE VALVE BOX SHALL NOT TRANSMIT SHOCK OR STRESS TO THE VALVE.

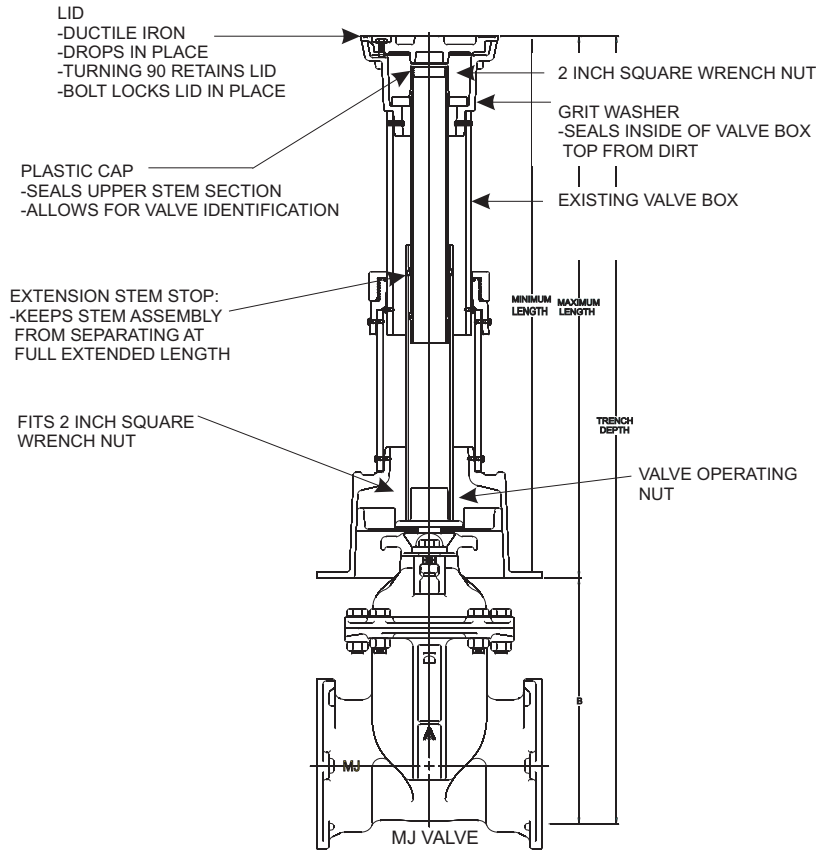

NOTE:

PADUCAH WATER WILL REQUIRE USE OF TRENCH ADAPTER & RETROFIT VALVE BOX FOR INSTALLATIONS WITH A DEPTH GREATER THAN 48 INCHES FROM TOP OF VALVE OPERATING NUT TO FINISHED GRADE UNLESS OTHERWISE SPECIFIED BY PADUCAH WATER STAFF.
TRENCH ADAPTER AND RETROFIT VALVE BOX INSERT DETAIL (SEE AMERICAN FLOW CONTROL PRODUCT INFORMATION AT www.acipco.com FOR DETAILS)
SEE TRENCH ADAPTER AND RETROFIT VALVE BOX INSERT DIMENSION CHART NO. TARVBI1 FOR VALVE SIZE, TRENCH DEPTH AND MODEL NUMBER